

## THE USE OF ATOMIC HYDROGEN LINE SHAPES FOR ABNORMAL GLOW DISCHARGE DIAGNOSTICS

I. VIDENOVIĆ, M. KURAICA and N. KONJEVIĆ

*University of Belgrade, Faculty of Physics, P.O.Box 368, 11001 Belgrade, Yugoslavia*

**Abstract.** The measurements of the shape of Balmer  $H_{\beta}$  line in the cathode fall and negative glow regions of the abnormal glow discharge in pure hydrogen are reported. The electric field intensity distribution is obtained using polarization-dependent Stark splitting of hydrogen lines. Two groups of excited neutrals with significantly different velocities have been detected.

### 1. INTRODUCTION

Recent spectroscopic measurements (Barbeau and Jolly, 1991; Ganguly and Garscaden, 1991) of the electric field intensity distribution, performed in conventional parallel – plates discharge structures, confirm that almost whole voltage drop takes part in the cathode fall region of glow discharges. On the other hand, studies of shapes of atomic-hydrogen lines (Benesch and Li, 1984; Petrović *et al.*, 1992; Kuraica and Konjević, 1992) in the negative glow region of hollow and plane-cathode glow discharges have shown hydrogen line shapes with extraordinary broad wings, which indicate the presence of excited hydrogen atoms with high velocities.

Both of these effects we have been faced within our experiment. As a light source we have used the plane cathode, cylindrical hollow anode abnormal glow discharge of the Grimm type (1967, 1968). This lamp is extensively used in atomic emission spectroscopy.

### 2. EXPERIMENT

Our discharge is laboratory made and fully described elsewhere (Kuraica *et al.*, 1992). Here we should mention only a few important details. The exchangeable hollow anode 30 mm long with inner and outside diameters 8 and 13 mm, has a longitudinal (15 mm long, 1.5 mm wide) slot for plasma observations. The water-cooled cathode holder has an exchangeable iron electrode 18 mm long and 7.60 mm in diameter which screws tightly onto its holder to ensure good cooling. Spectra recordings were performed side-on (see Fig.1.), in 1/8 mm steps along the discharge axis. The gas flow through the discharge of about 500 cm<sup>3</sup>/min STP was sustained at a pressure of 150 Pa by means of a needle valve and two-stage mechanical vacuum pump. To run the discharge a 0-2 kV, 0-100 mA dc voltage stabilized power supply was used. In series with the

discharge and power supply a ballast resistor of 10 k $\Omega$  was placed. The measurements were performed at 20 mA discharge current and 640 V applied to the electrodes.

After polarization (Glan Thompson prism), the light from the plasma source was focused with unity magnification (maximum solid angle 6°) onto the entrance slit of scanning monochromator-photomultiplier system (2 m focal length with 600 g/mm reflection grating and reciprocal dispersion 0.74 nm/mm). The measured instrumental half-width with 15 mm slits was 0.014 nm. The signals from detection system were A/D converted, collected and processed by PC.

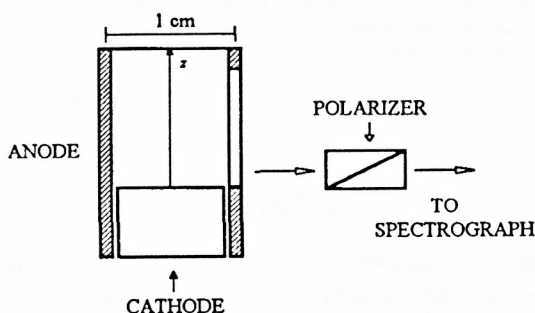

Fig. 1. Schematic diagram illustrating the discharge and polarizing prism.

### 3. RESULTS AND DISCUSSION

Spectra recordings along the discharge axis from the cathode surface enables us to observe continuously both cathode fall and negative glow region of the discharge.

**Cathode fall region.** Typical profiles measured in the vicinity of the cathode are shown in Fig.2. Two distinctive maximums of  $H_{\beta}$  profiles, recorded with polarizer axis parallel (Fig.2.a.) and perpendicular (Fig.2.b.) to the discharge axis, indicate that the presence of external electric field predominantly determines the line shapes in this part of the discharge. Following the theory of the linear Stark effect (Condon and Shortley, 1977) we assumed that overall profile of both components (linearly polarized, parallel to the electric field ( $\mathbf{E}$ ), i.e.  $\pi$ -component, and circularly polarized one in the plane perpendicular to  $\mathbf{E}$  -  $\sigma$ -component) of  $H_{\beta}$  line consists of ten sub-components. The distance between these sub-components is equal to the integer multiple of (Ryde, 1976) :

$$\Delta\lambda_0(\text{nm}) = 1.51 \times 10^{-3} \times E \text{ (kV/cm)}.$$

To the each sub-component we have assigned the Gauss function which takes into account the Doppler and instrumental broadening. Considering overall profile as the sum of Gaussians, we have fitted the experimental data with the resulting function, taking the electric field intensity and temperature of H-atoms as variables. The fitted functions are represented by dashed lines in Fig.2. Knowing the electric field

intensity from the first fit, we have performed additional fitting of the far wings of the profiles with smaller amplitude and higher temperature. The results of those calculations are represented by short dashed lines, while overall profiles (sum of both fitting procedures) are shown by solid lines in Fig.2.

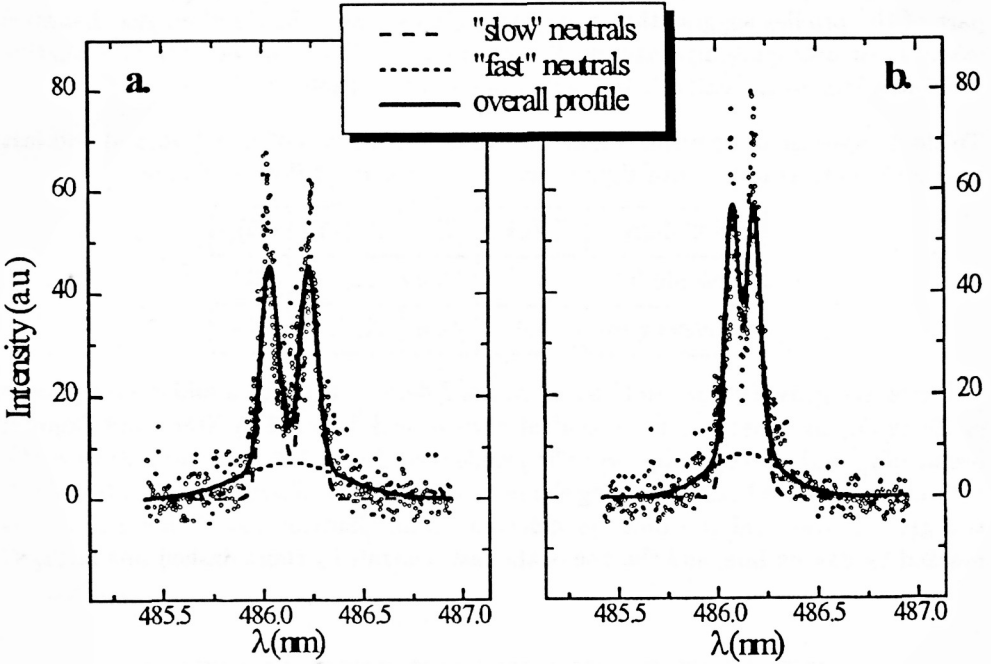

Fig. 2. Typical  $H\beta$  profiles recorded at 0.12 mm from the cathode : a.  $\pi$ -component, b.  $\sigma$ -component. Discharge conditions : 150 Pa, 20 mA, 640 V.

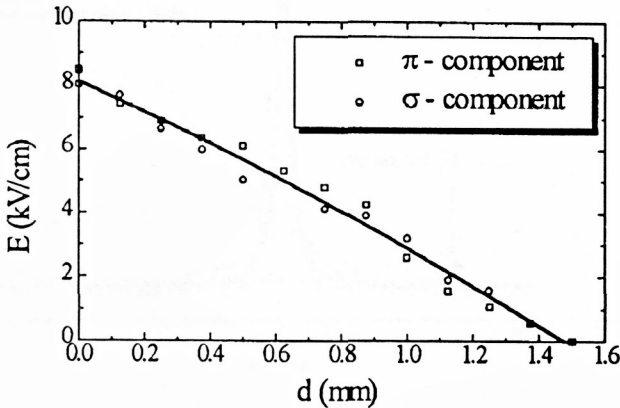

Fig. 3. Electric field intensity vs. distance from the cathode.

Applying this procedure at each recorded position, the decrease of the electric field intensity along the cathode fall region has been obtained (see Fig.3). The integral under the electric field curve is equal 633 V ( $\pm 5\%$ ), which is very close to the applied voltage (640 V) to the electrodes of the discharge. So, we may conclude that in Grimm's type glow discharge the whole voltage drop takes part in cathode fall region. The large difference between temperatures calculated from higher and lower part of the profiles suggest that two groups ("slow" and "fast") of excited H-atoms exist. Their average temperatures,  $T_s$  and  $T_f$  respectively, as well as their relative concentrations in the cathode fall region are given in Table 1.

**Table 1.** Average temperatures and relative concentrations of slow (index s) and fast (index f) neutrals in the investigated regions of abnormal glow discharge.

REGION	$T_s$ (eV)	(%) <sub>s</sub>	$T_f$ (eV)	(%) <sub>f</sub>
cathode fall	4.7	63.4	121.4	36.6
negative glow	8.4	49.5	120.3	14.4

**Negative glow region.** In this region, the difference between  $\pi$  and  $\sigma$ -component of  $H_\beta$  profile disappears and the central narrow peak induced by Stark and Doppler broadening in the plasma appears. The profile recorded at 1.62 mm distance from the cathode is shown in Fig.4. Applying the same algorithm as above, with condition  $E=0$ , two groups of excited H-atoms are detected again. Contribution of slow neutrals is marked by dashed line, and the one of the fast neutrals by short dashed line in Fig.4.

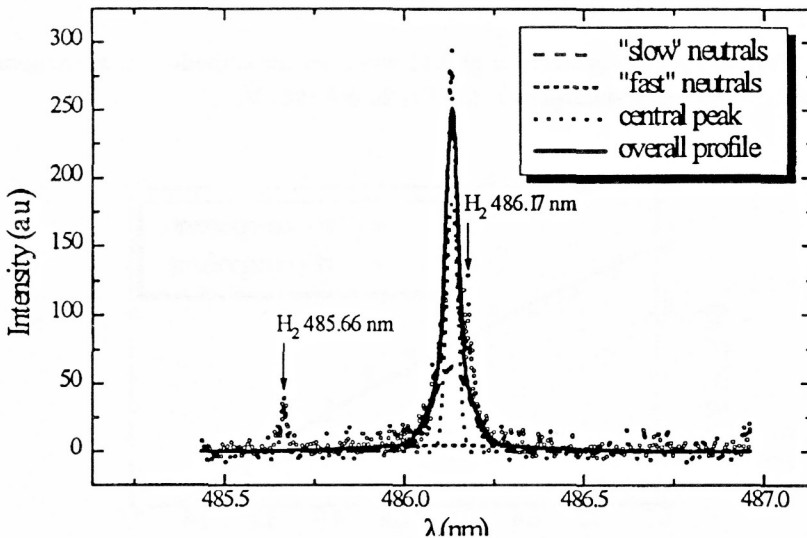

Fig. 4.  $H_\beta$  profile recorded at 1.62 mm from the cathode. Discharge conditions same as above.

In the same figure the central narrow peak (dotted line) is shown, but is already considered by Kuraica and Konjević (1992). Average temperatures and relative concentrations of slow and fast neutrals in the negative glow region are also given in Table 1.

#### 4. CONCLUSIONS

Measurements of the line shapes in the cathode fall and negative glow region of the plane-cathode abnormal glow discharge indicate the presence of two effects responsible for broadening of hydrogen lines: linear Stark effect from external electric field in cathode fall region only, and Doppler broadening from two groups of excited H-atoms with considerably different velocities - in both regions. The origin of slow and fast neutrals is the subject of our further investigations.

#### References

- Barbeau, C. and Jolly, J. : 1991, *Appl. Phys. Lett.*, **58**, 237.  
 Benesch, W. and Li, E. : 1984, *Opt. Lett.* **9**, 338.  
 Condon, E. U. and Shortley, G. H. : 1977, *The theory of atomic spectra*, University Press, Cambridge.  
 Ganguly, B. N. and Garscadden, A. : 1991, *J. Appl. Phys.*, **70**, 621.  
 Grimm, W. : 1967, *Naturwissenschaften*, **54**, 586.  
 Grimm, W. : 1968, *Spectrochim. Acta*, **23B**, 443.  
 Kuraica, M. and Konjević, N. : 1992, *Phys. Rev.*, **A46**, 4429.  
 Kuraica, M., Konjević, N., Platiša, M. and Pantelić, D. : 1992, *Spectrochim. Acta*, **47B**, 1173.  
 Petrović, Z. Lj., Jelenković, B. M. and Phelps, A. V. : 1992, *Phys. Rev. Lett.* **68**, 325.  
 Ryde, N. : 1976, *Atoms and molecules in electric fields*, Almqvist & Wiksell International, Stockholm.